



Metal Roof Certification & Listing Program

Certification Report



11033-007-KCI

145 Limekiln Road, Suite 100B
New Cumberland, PA 17070
www.keystonecerts.com

Issue Dated: 12/12/2017
Revision Date: 12/22/2020
Expiration Date: 12/22/2025

Construction Specifications Institute (CSI) Category:

Division: 07 00 00 – Thermal & Moisture Protection

Section: 07 41 13 – Metal Roof Panels

1. Program Licensee:



Reed's Metals, Inc.
19 E. Lincoln Drive NE
Brookhaven, Mississippi 39601
800-581-4645
<https://Reed'smetals.com/>

2. Certified Roof Covering:

Reed's Metals Model 29 Ga. Residential Panel (Re-Roofing) through-fastened non-structural metal roof panels installed over minimum #2 1x4 purlins over nominal 7/16" OSB sheathing, with or without asphalt shingles and one layer of 30# felt paper between the purlins and the roof deck, for use in re-roofing applications.

3. Scope of Certification:

This Certification Report provides technical data substantiating that the use of the certified roof panels in the evaluated roof systems are in compliance with the following:

- 2020 Florida Building Code - Building, 7th Edition, Section 1504.3.2 and 1504.7.
- Florida Product Approval Rule 61G20-3.

Properties Evaluated:

- Wind Uplift Resistance
- Impact Resistance

This Certification Report was used in the qualification of [Florida Product Approval FL 24508-R1](#).

4. Evaluated Roof System Description:

4.1. **Roof Covering:** 29 Ga. Residential Panel (Re-Roofing) are through-fastened non-structural metal roof panels 36" wide (coverage) and cold roll-formed from minimum 29 gauge (0.015" / 0.381mm coated thickness) minimum Grade 80 steel sheet. The panels are coated per the following:

- aluminum-zinc alloy coated per ASTM A792, minimum AZ50

Or:

- zinc-coated per ASTM A653, minimum G-90

And Optionally:

- pre-painted per ASTM A755

and shall be installed in accordance with the manufacturer's instructions and this Certification Report.

4.2. **Roof Deck:** 29 Ga. Residential Panel (Re-Roofing) metal roof panels are certified for use over minimum #2 1x4 purlins over nominal 7/16" OSB sheathing complying with 2020 Florida Building Code, Section 2303.1.8, with a minimum slope of 4% (1/2:12). The 1x4 purlins were attached through the roof deck and into the 2x10 wood rafters with (2) #9 x 2-1/2" deck screws at 24" O.C.



Metal Roof Certification & Listing Program

Certification Report

11033-007-KCI



4.3. **Anchorage:** 29 Ga. Residential Panel (Re-Roofing) metal roof panels shall be through-fastened to the minimum #2 1x4 purlins using #9-15 x 1-1/2" SFS Intec Woodgrip HWH SD with EDPM-sealing washer or approved equivalent in the fastener patterns described in Appendix 1.

5. Installation

29 Ga. Residential Panel (Re-Roofing) metal roof panels shall be installed in accordance with the 2020 Florida Building Code Sections 1507.4 & 1511, the manufacturer's published installation instructions and this Certification Report.

The manufacturer's installation instructions shall be made available at the time of installation. If there are differences between this report and the manufacturer's installation instructions, this report shall take precedence.

6. Product Performance

The performance of the 29 Ga. Residential Panel (Re-Roofing) metal roof panels described in this Certification Report has been demonstrated via testing in accordance with the following referenced standards:

- UL 580-06, *Tests for Uplift Resistance of Roof Assemblies.*
- UL 1897-2012, *Uplift Tests for Roof Covering Systems.*
- FM 4470-2016, Section 4.6 Resistance to Foot Traffic Test.

As tested & reported by the following independent accredited laboratory:

Laboratory	Report Ref.
Force Engineering & Testing	101-0210T-17C & D
	101-0241t-09A

The FM 4471-10 test standard is equivalent to the FM 4470-2016 test standard.

6.1. Wind Resistance

The allowable Ultimate Wind Uplift Capacity for Reed's Metals 29 Ga. Residential Panels (Re-Roofing) anchored as described in Appendix 1, when tested in accordance with the referenced standards with an applied safety factor of 2.0 are found in Table 1.

Table 1

Description	Anchor Pattern	Max Design Uplift Pressure
Over minimum #2 1x4 purlins over nominal 7/16" OSB sheathing, with or without Asphalt Shingles and 30# Felt Between Purlins and Sheathing	A 9"-9"-9"-6.5" 24" O.C.	-86.0 psf
	B 9"-9"-9"-6.5" 12" O.C.	-176.0 psf

7. Conditions of Use

29 Ga. Residential Panel (Re-Roofing) metal roof panels must be insulated against other materials or metals including concrete, lead, copper and treated lumber that



Metal Roof Certification & Listing Program

Certification Report

11033-007-KCI



contains corrosive materials. Lap sealant is required for all installed slopes below 3:12 (25%).

8. Limitations of Use

29 Ga. Residential Panel (Re-Roofing) metal roof panels are not qualified for use in the High Velocity Hurricane Zone (HVHZ).

Fire classification, shear diaphragm design, roof deck design & attachment to supporting members are not within the scope of this Certification Report. Roof support framing shall comply with 2020 Florida Building Chapter 16 for structural loading and Code Chapter 23 for wood.

9. Licensed Manufacturing Facilities

This Certification Report is applicable only to Reed's Metals 29 Ga. Residential Panel (Re-Roofing) metal roof panels manufactured at the following locations. Each licensed facility is subject to periodic inspection by Keystone Certifications to verify conformance with Keystone Roof Covering Certification & Listing Program requirements:

<p>Reed's Metals, Inc. 19 E. Lincoln Drive NE Brookhaven, Mississippi 39601</p> <p>Reed's Metals Inc. 16454 SE Highway 19 Cross City, Florida 32628</p>

10. Identification

Reed's Metals 29 Ga. Residential Panel (Re-Roofing) metal roof panels represented by this report shall be

identified with Keystone Roof Covering Certification & Listing Program certification labeling illustrated below, to be applied to individual panels, packaging, invoicing or bills of lading:



Aaron Shultz
Validation Manager

Appendix 1

Notes: *Lap sealant is required for all installed slopes below 3:12 (25%).*

Anchor Pattern A

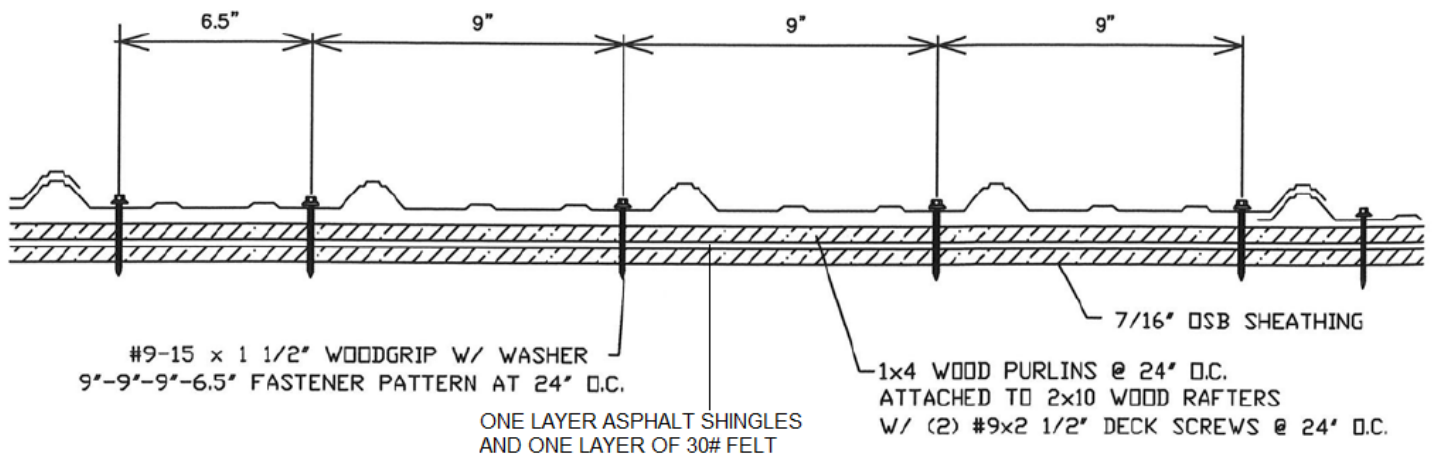

Anchor Pattern B

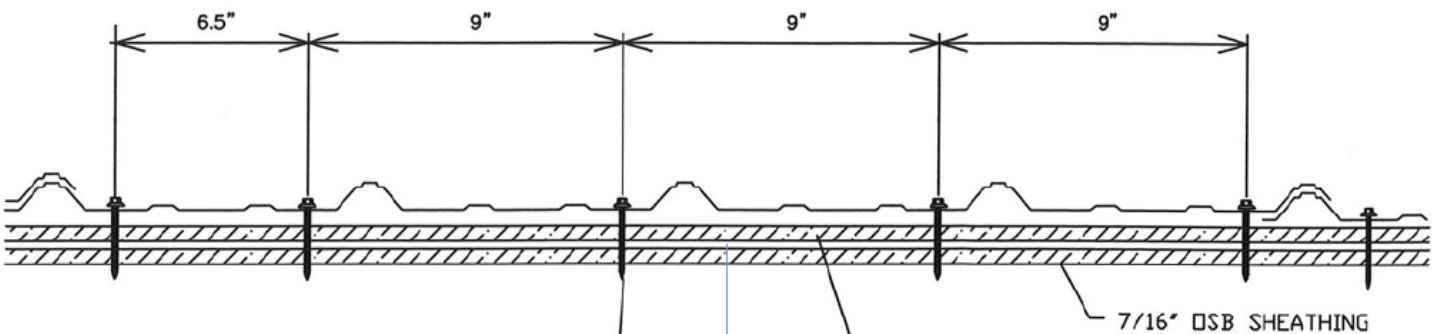



Metal Roof Certification & Listing Program

Certification Report

11033-007-KCI



145 Limekiln Road, Suite 100B
New Cumberland, PA 17070
www.keystonecerts.com

Issue Dated: 12/12/2017
Revision Date: 12/22/2020
Expiration Date: 12/22/2025

Certificate Revisions

Rev #	Date	Description
0	12/12/2017	Initial issuance.
1	1/26/2018	Added FL Approval No, inserted the word "minimum" before material specifications, made asphalt shingles optional.
2	9/3/2019	Updated ANSI Logo to proper requirements. Updated signature block to new Reviewer.
3	12/22/2020	Updated to 2020 Florida Building Code.

Refer to www.keystonecerts.com to ascertain the ongoing status of this Compliance Certificate. Approval of building products and/or materials can only be granted by the building official having jurisdictional legal authority. Keystone Certifications, Inc. does not endorse or make warranties with respect to product performance or suitability of a product for a given use.